

ACCESSORY SETUP INSTRUCTION

FRONT WINDSHIELD -- PN 9DQV-805200-3000

VALID FOR: CFORCE 400 & 500 TOURING

BEFORE YOU BEGIN: Read and understand the instructions before starting any work. Make sure that all parts are ready and that you have all the tools required for assembly.

NOTE: CFMOTO shall not be liable for any damage caused by incorrect assembly. CFMOTO recommends that all original accessories be assembled by an authorized CFMOTO dealer.

Before assembly, park the vehicle on a flat surface, put the transmission gear into Park (P) and turn off the key switch.

Zhejiang CFMOTO Power Co., Ltd. All rights reserved. Reproduction of this document, even in part, as well as copying of all kinds, is permitted only with the express written permission of the copyright owner.

MEANING OF SYMBOLS

 - Indicates information with more details or tips.

 - Indicates information of warning or danger.

PARTS LIST:

ITEM	PART NAME	PART NUMBER	QTY.	REMARK
1	FRONT WINDSHIELD	9DQV-805200-3000	1	For structure reference only
2	BRACKET A, LH WINDSHIELD	9DQV-805201-3000	1	
3	BRACKET A, RH WINDSHIELD	9DQV-805202-3000	1	
4	BRACKET B, LH WINDSHIELD	9DQV-805203-3000	1	
5	BRACKET B, RH WINDSHIELD	9DQV-805204-3000	1	
6	SCREW M6x22	30102-060022870	4	
7	SCREW M6x16	30102-060016870	6	
8	FRONT WINDSHIELD	9DQV-805205-3000	1	
9	WASHER	30303-060070	6	
10	NUT	30206-060570	10	
11	RUBBER BUSHING	6KJ0-120004	4	
12	RUBBER SLEEVE LINER	5020-031002	4	
13	SCREW M8x70	30102-080070870	4	

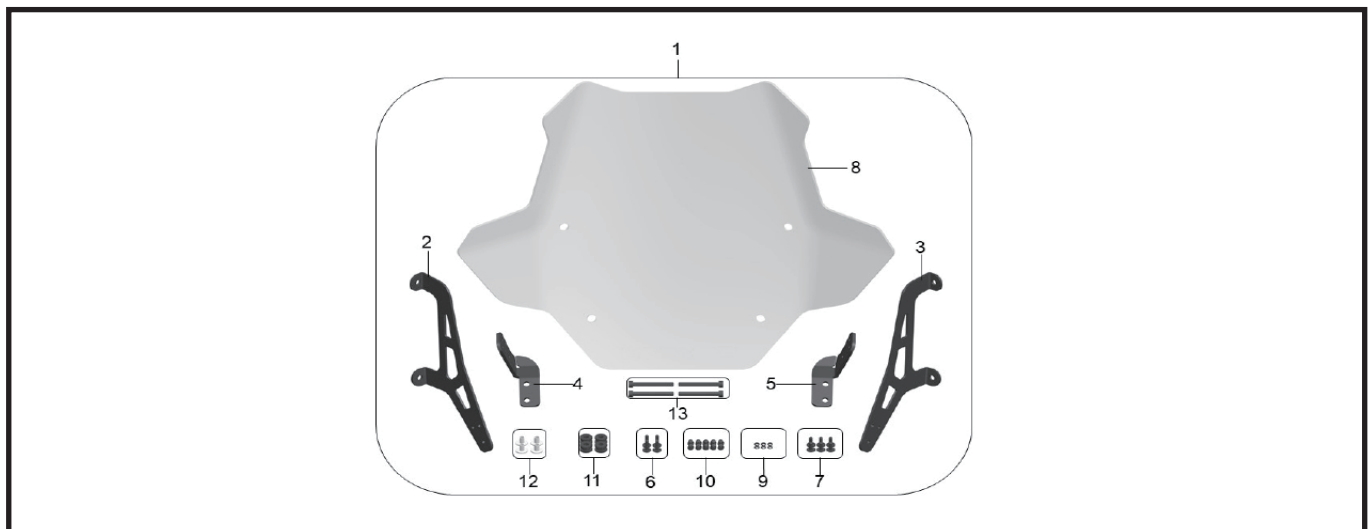

TOOL LIST:

ITEM	DESCRIPTION	QTY.	REMARK
1	PROTECTIVE GLOVES	1	Recommended tools
2	10mm WRENCH	1	
3	4mm ALLEN WRENCH	1	
4	6mm ALLEN WRENCH	1	

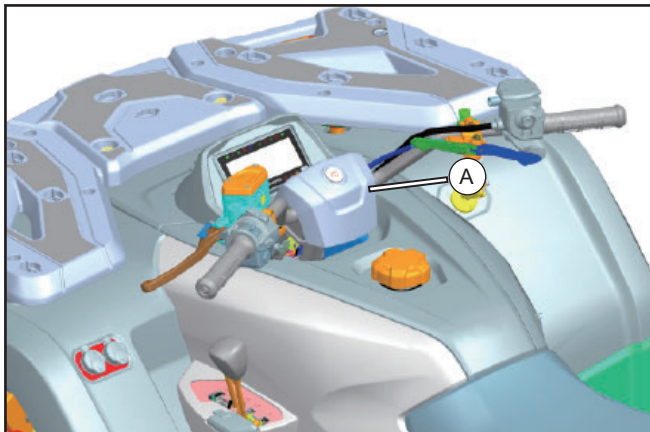

// Pull up and remove the handlebar guard (A).

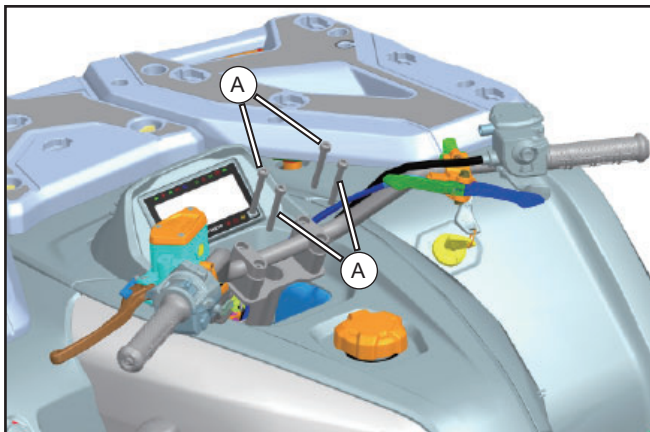

// Remove the four handlebar clamp screws (A).
 // **NOTE:** These screws will not be reused.

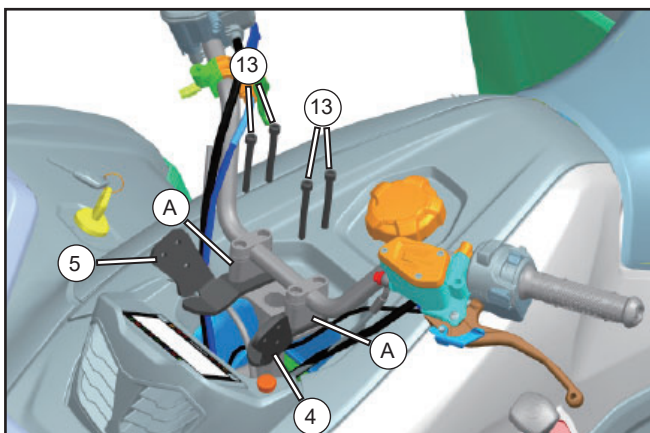

// Place the LH & RH windshield bracket B (4 & 5) under the handlebar clamp blocks (A) as shown, align the thread holes, then install and torque the M8×70 screws (13) to specification.
 // **NOTE:** When possible do not disturb the handlebar clamp block positions for easier reassembly. Realign the handlebar position as necessary and tighten the screws to the proper torque specification.

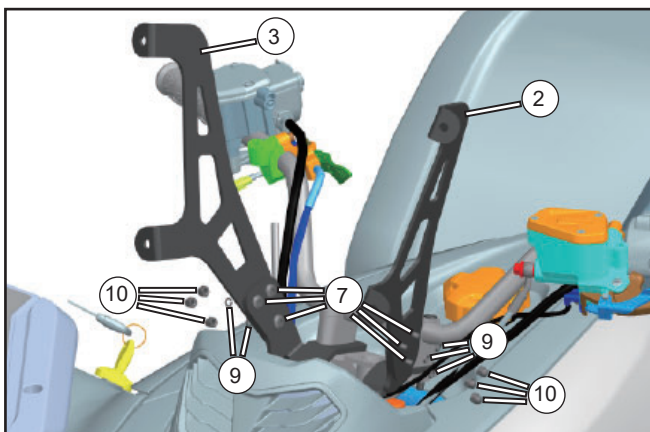

// Align the corresponding holes of LH & RH windshield brackets A (2 & 3) to LH & RH windshield brackets B (4 & 5), then install M6×16 screws (7), washers (9), and nuts (10) in each hole and tighten them.

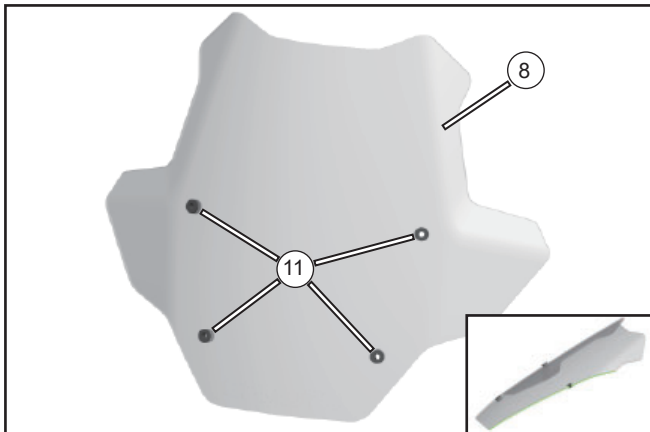
ASSEMBLY AND INSTALLATION

// Install the rubber bushings (11) into the corresponding holes on the front windshield (8).

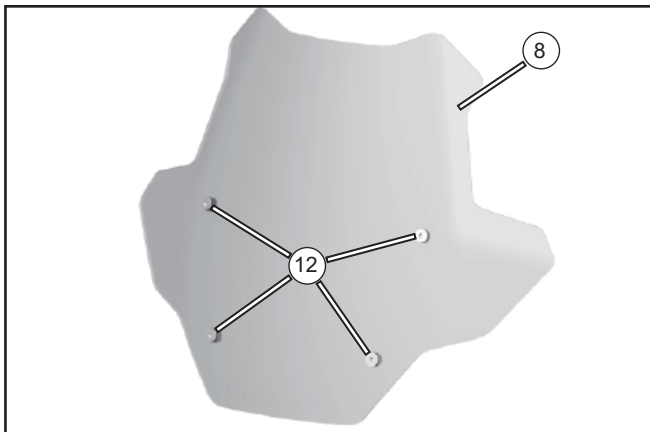

// Install the rubber sleeve liners (12) into corresponding holes on the front windshield (8).

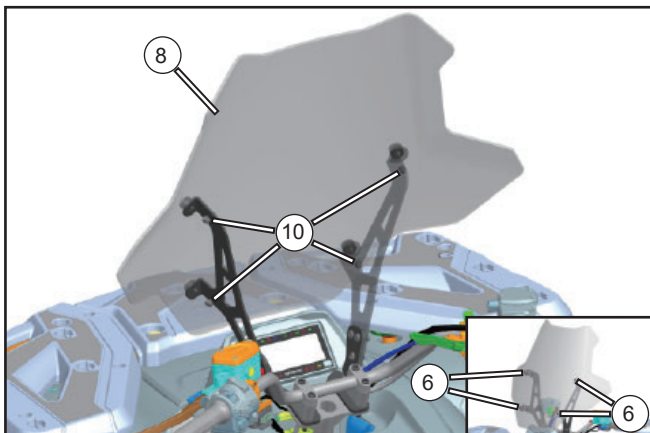

// Align the holes on the front windshield (8) to the windshield brackets, then install the supplied M6x22 screws (6) and nuts (10). Tighten the fasteners sufficiently, using caution not to over-tighten.

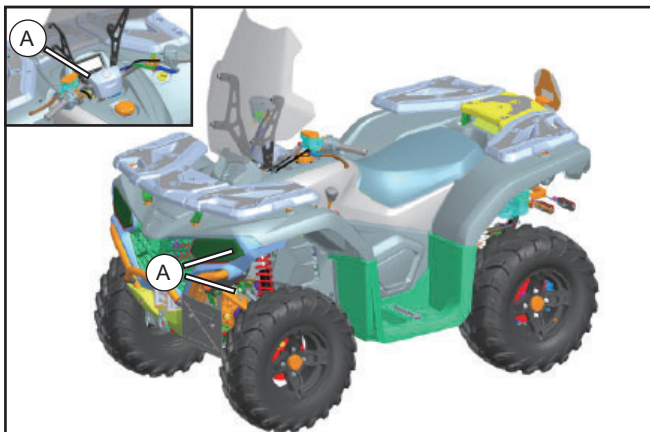

// Reinstall the handlebar guard (A).